

# BURNISHING PRODUCTS



- **Mirror-like surface finish**
- **Accurate sizing**
- **Work hardened surface**
- **Low cost & Easy to use**

MANUFACTURED BY:





1760 Tuttle Avenue - Dayton, Ohio 45403

**TABLE OF CONTENTS**

How Roller Burnishing Works	3
Advantages of Roller Burnishing	3
Surface Finishes	4
Preparation for Burnishing	4
Feed Pattern	4
Cutting Tool Geometry	4
Recommended Feeds and Speeds	5
Stock Allowance and Surface Finish Chart	5
Setting the Roller Burnishing Tool	6
Caring for the Roller Burnishing Tool	6
Multiple Surface Burnishing Tools	6
Cup Plug Expanders	6
Override Adapters	6
Sizing Tools	7
Tube End Expanders	7
Mechanical Joining Tools	7
Burnishing Tool Dimensions	8
Ordering Procedure	9
Intermediate Tips	9
Internal Burnishing Tools and Spare Parts	
5400 I.D. Series (.187" to 3.312")	10 to 15
5610, 5611 & 5612 I.D. Series (3.343" to 5.500")	16 to 17
Diamond Burnishing Tool	18
Carbide Roll Burnishing Tools	19

**World Headquarters:**  
**Elliott Tool Technologies, Ltd.**  
**and**  
**Monaghan & Associates, Inc.**

*Elliott Tool Technologies, Ltd., manufactures the products shown in this catalog.*

*Monaghan & Associates, Inc. is the **EXCLUSIVE WORLDWIDE MARKETING AGENT** for all products shown in this catalog.*

*We reserve the right to modify the design or construction of the equipment described in this catalog and to furnish it, as altered, contained herein, without further reference to the illustrations or information.*

*We take great pride in the quality of workmanship and selection of alloy steels for all our tools. Therefore, we guarantee the replacement of any part returned which has been determined to be defective in workmanship or material.*

**MANUFACTURED BY:**



[www.elliott-tool.com](http://www.elliott-tool.com)

Tel 1 800 732-4565  
 Fax 937 259-9241

## How Roller Burnishing Works

Roller burnishing is a **chipless machining method** which cold works the metal without cutting or abrading the surface. It **removes no metal** but rather compresses, or “irons out”, the peaks of a metal surface into the valleys, generating a dense and uniform surface. Roller burnishing **improves surface finish** and results in **dimensional accuracy**.

## The Roller Burnishing Tool

The roller burnishing tool consists of a **cage**, which retains a series of **precision tapered rolls** rotating around, and bearing on, an **inversely tapered mandrel**.

Within the work-piece, the tool is sized so that the roll develops a pressure that exceeds the yield point of the softer work-piece. The **cold working action** will improve minor surface irregularities and tool marks resulting in a **low microinch surface finish**.

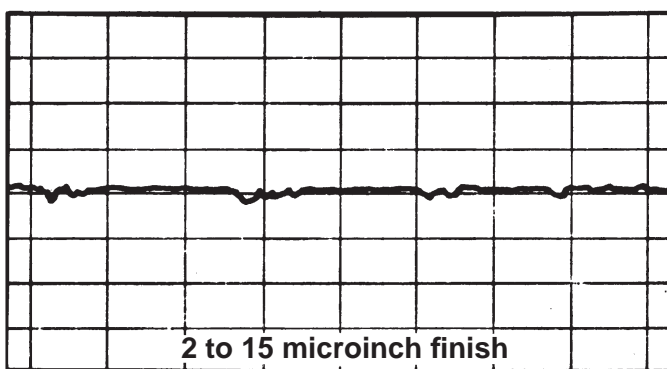
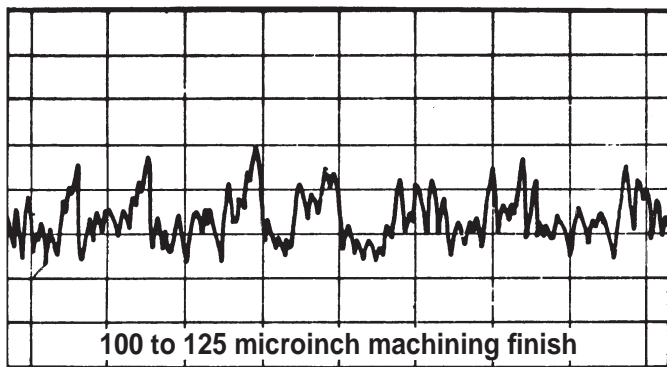

## Surface Finishes

In production work involving surface textures having a **100 to 125 microinch machining finish**, burnishing tools can produce a 2 to 16 microinch finish in a single pass. In bronze and aluminum, readings of **2 to 8 microinch** can be achieved with a burnishing tool. In steel, comparable readings would be **2 to 8 microinch**. In cast iron, a **12 to 24 microinch** finish can be expected.

## Advantages of Roller Burnishing

Roller burnishing imparts three major characteristics: **accurate sizing**, a **low micro-finish** and **hardening of the surface**. Roller burnishing will obtain a high quality finish and eliminate the need for secondary operations such as grinding, honing and lapping.

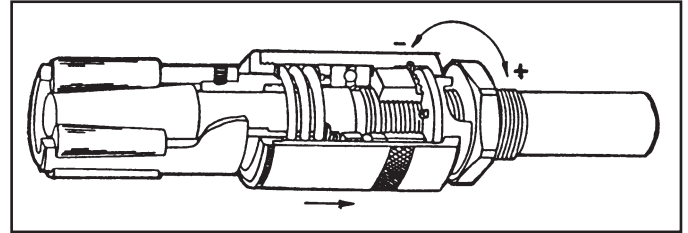

The roller burnishing tool incorporates a built-in micrometer, which allows for .0001” adjustments in tool size.

**Sizing** with roller burnishing is influenced by the pre-machined surface. Roller burnishing in steel can result in a 25% size improvement. A 50% improvement in high ductility materials can be expected. In low ductility materials, such as cast iron, improvement is about 20%.

The low micro-finish, combined with a hardened and denser surface, substantially increases part wear, life and corrosion resistance. The added strength improves the part’s fatigue resistance, resulting in decreased failures. The cold working condenses the grain structure of metal, producing an increase in surface hardness from 50% to 100%, within a penetration of .010” to .030” on the part’s surface.

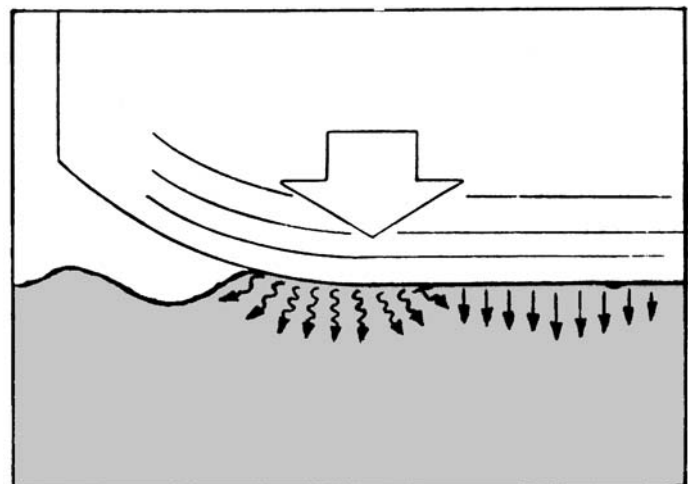

In roller burnishing, the material is elastically deformed to a given depth below the surface. The result is compressive stresses at the surface. In turn, this increases the resistance of the material to fatigue failure because any external forces must first overcome these residual stresses.

## Surface Finishes

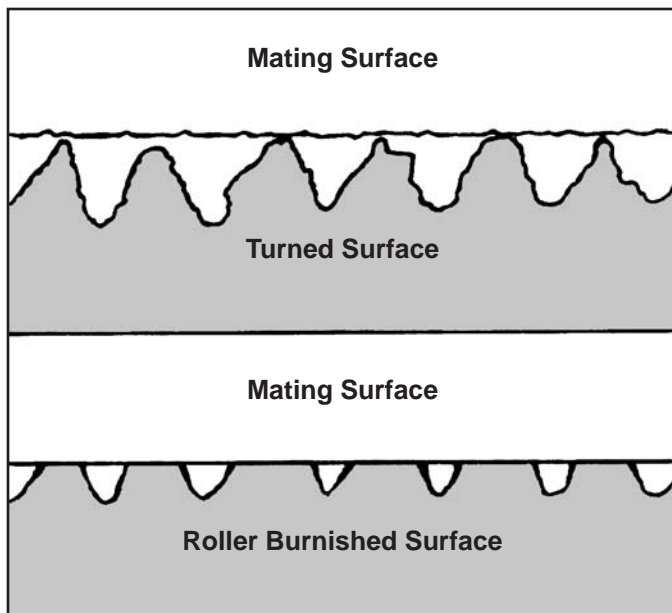

Varying surface finishes are obtained in the machining of mating parts. Machined surfaces result in a loose fit on mating parts. Surfaces which have been roller burnished have a higher bearing capacity and abrasion resistance. Roller burnishing improves this fit by providing a larger contact area between the surfaces.

Pistons, valves, cylinders and other parts with similar functions require continuous lubrication. Roller burnishing will leave valleys in the surface of these parts, which act as oil reservoirs, extending part life. This can be achieved by controlling the burnishing size and hole size. Roller burnishing has resulted in product improvement and cost savings to the hydraulic cylinder industry.

The electric motor industry has derived great benefits from roller burnishing to reduce noise levels in moving parts.

Heat, resulting from friction, has a direct effect on surface finish. This temperature rise causes dimensional changes that can have an adverse effect on the function of the parts. By roller burnishing, it is possible to reduce friction by up to 30%.

Burnishing tools can be used on any spindle driven machine. The burnishing tool or work piece can rotate, the roller burnishing process works well either way. No special skills are required to operate a burnishing tool. Simply set the tool to the proper size and the operator will turn out precision finished parts throughout the production run.

## Preparation for Burnishing

Several factors should be considered in preparation of the work piece. These are **feed pattern**, **cutting tool geometry** and **stock allowance**.

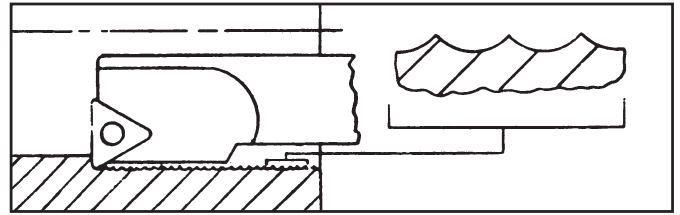

**Feed Pattern** the peak and valley effect, which is generated by the cutting tool. This is an ideal surface finish for roller burnishing.

An extremely smooth bore is not required to perform roller burnishing. However, gouges and tears in the surface caused by the drilling or reaming operation and/or the single point turning will be very difficult to roller burnish. These gouges and tears will cause a change in the surface micro-finish as well as a change in the diameter. Deep gouges will remain visible after the burnishing operation.

A finer machined surface is required before the burnishing operation with less ductile materials, such as cast iron and heat treated steel above R<sub>c</sub>35.

Ductile materials, such as brass, aluminum and annealed steels can have a rougher machined surface. Very finely machined surfaces can accept only a slight size change when burnished. Some 25% to 50% less material can be displaced from a reamed surface versus a surface machined with a single point tool.

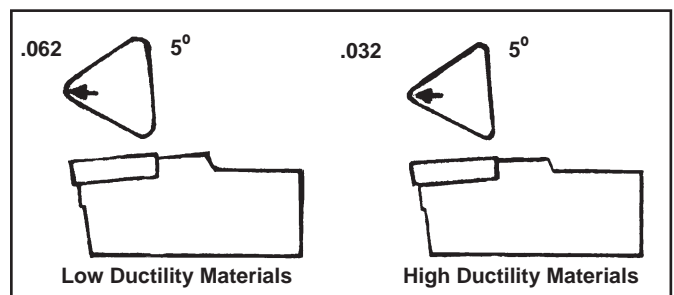

**Cutting Tool Geometry** in ductile material with single point tools (a 1/32" nose radius with a minimum 5 degree back taper) is recommended. For best results, feed the cutting tool at a feed rate sufficient to produce a surface in the 80 to 120 microinch range with a consistent peak and valley pattern. For less ductile materials, use a feed rate of about 50% less than that of more ductile materials. The result should be a 60 to 100 microinch surface finish.

## RECOMMENDED FEEDS AND SPEEDS

### Internal Roller Burnishing Tools

Hole Size	Inch Per Revolution		Speed Rev/Min
	Min.	Max.	
.125	.004	.006	1500
.187	.004	.006	
.250	.006	.008	
.375	.009	.013	1000
.500	.011	.016	
.625	.015	.022	600
.750	.018	.027	
.875	.020	.030	
1.000	.026	.039	300
1.250	.038	.057	
1.500	.045	.067	200
1.750	.046	.069	
2.000	.056	.084	

Hole Size	Inch Per Revolution		Speed Rev/Min
	Min.	Max.	
2.250	.060	.090	170
2.500	.066	.099	
2.750	.043	.064	
3.000	.045	.067	120
3.250	.049	.073	
3.500	.059	.083	100
3.750	.062	.093	
4.000	.065	.097	
4.250	.071	.106	85
4.500	.072	.108	
4.750	.078	.117	70
5.000	.081	.121	
5.500	.093	.140	

### STOCK ALLOWANCE/SURFACE FINISH CHART

Tools with non-feed cages (full bottom tools) must always be machine fed. Machine settings are approximate. Always set the machine faster than the feed rate of the burnishing tool. Feeds can be adjusted upward 25% to 50%.

	Work-piece Size Range	Internal Surfaces			External Surfaces		
		Stock Allowance	Surface Finish		Stock Allowance	Surface Finish	
			Machined	Roller Burnished		Machined	Roller Burnished
High Ductility	0.125 to 0.484	0.0004	80	8	0.0004	80	8
	0.500 to 1.000	0.0007	125	8	0.0005	100	8
	1.031 to 2.000	0.0007	60	8	0.0005	60	8
	2.031 to 6.500	0.0015	125	8	0.0010	180	8
		0.0010	60	8	0.0007	100	8
		0.0020	125	8	0.0010	180	8
Low Ductility	0.125 to 0.484	0.0015	60	8	0.0010	125	8
	0.500 to 1.000	0.0020	125	8	0.0015	300	8
	1.031 to 2.000	0.0030	200	8	0.0020	500	8
	2.031 to 6.500	0.0004	80	18	0.0003	60	18
		0.0007	100	18	0.0005	90	18
		0.0007	90	18	0.0005	100	18
	0.0010	125	18	0.0007	140	20	
	0.0010	125	18	0.0005	100	18	
	0.0015	180	20	0.0010	180	20	
	0.0015	120	18	0.0010	125	18	
	0.0015	160	18	0.0015	140	18	
	0.0020	200	24	0.0015	200	20	

**High Ductility Materials** have more than 18% elongation and less than R<sub>c</sub>32. They include: annealed steel, stainless steel, aluminum, brass, bronze and malleable iron.

**Low Ductility Materials** have less than 18% elongation and a maximum hardness of R<sub>c</sub>40. They include: gray iron, nodular iron, heat-treated steel, magnesium alloys and hard copper alloys.

**Stock Allowances** are based on an 80 to 180 microinch surface finish consisting of uniform peaks and valleys. The amount of stock allowance varies with job conditions, material properties, wall thickness, nature of the machined surface and quality of surface finish desired. Figures shown are a starting point for part preparation.

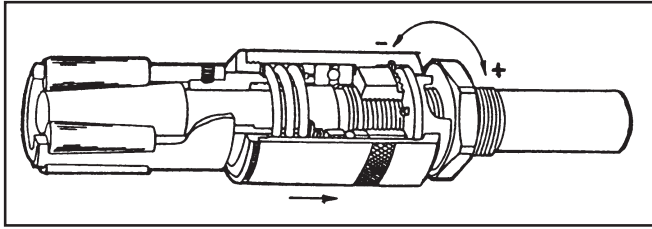

### Setting the Burnishing Tool

Loosen the lock nut. Pull back the spring-loaded housing. Turn it to the left to *increase* the diameter and to the right to *decrease* the diameter.

Gradually increase the diameter of the tool, while sliding the tool into (or onto) the work-piece. When the rolls contact the surface to be burnished, resistance to the sliding motion will increase. Burnish a sample work-piece and measure the size and finish. When the desired size and finish is accomplished, tighten the lock nut.

### Caring for the Roller Burnishing Tool

**Lubrication:** A continuous stream of clean lubricant, in sufficient volume to flush and clean the tool and work-piece, should be provided during operation.

Use any standard grade of lightweight, low-viscosity lubricating oil for most metals. For aluminum or magnesium alloys, highly refined paraffin base oil of low viscosity will work well. Water-soluble lubricants are also acceptable.

Any sulfur, mineral or soluble oil that is recommended for achieving a fine finish may be used, provided it is compatible with the metal or alloy being roller burnished.

**Filtration:** All lubricants should be filtered. Without filtration, chip particles flushed into the area to be burnished can distort the bore and mar the fine finish.

**Maintenance:** When properly used, the roller burnishing tool requires only routine maintenance. Rolls, cages and mandrels should be examined at regular intervals and replaced when necessary. Always replace a complete set of rolls since there will be some sacrifice of tolerance and finish quality if new and used rolls are run simultaneously.

**Tool Alignment:** A minimal misalignment of .003" to .004" will not adversely affect the tool or the surface finish. However, if the tool alignment deviates more than .005" from the axis of the work-piece, bending stresses can occur. This could lead to fatigue failure of the mandrel tip. Tool whip is more likely than work-piece whip. Correct alignment is more important when the tool rotates.

**Axial Movement:** During the release cycle, axial movement is prevented by rigidly mounting the tool shank in the spindle. This is particularly important in the case of large, heavy tools that work in a vertical position.

**Multiple-Spindle Automatics:** The roller burnishing tool should be mounted in a top position to minimize chip contamination from the other metal-cutting operations.

**Override Adapters:** These are recommended on burnishing tools which require an external force to produce the burnish pressure. These tools reduce the risk of over-rolling and flaking the surface.

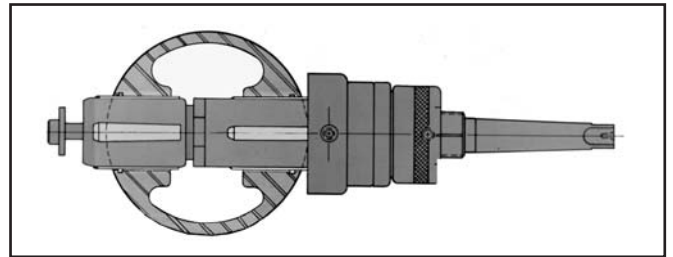

### Multiple Surface Tools

In long production runs, this tool is used to an advantage for the simultaneous finishing of two or three diameters or surfaces with large interruptions. Diameters and flat faces or angles can be burnished simultaneously. Internal and external combination burnishing tools are also used.

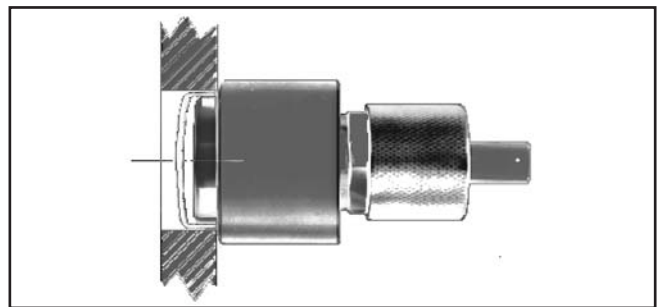

### Cup Plug Expander

The tool shown above is used to install cups in motor blocks, heads and other similar assemblies. The cup plug expander offers substantial savings over the pipe or welch plug. It can be used to expand rings or sleeves inside any bore diameters.

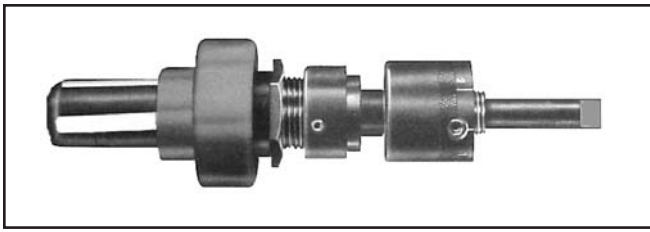

### Sizing Tools

Sizing tools, or parallel expanding tools, are used where intersecting holes or thin wall sections exist. These tools are used on I.D. or O.D. applications where high demands on straightness and parallelism are required. The tools enter the work piece with the rolls retracted. Once in position, the rolls are expanded radially to create size.

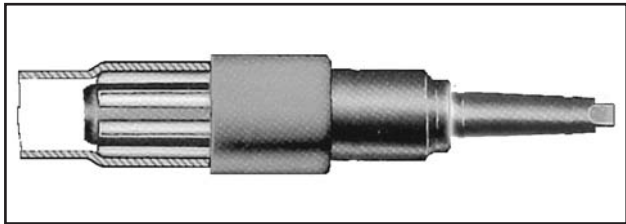

### Tube End Expander

The tube end expander is used to join tubular products. Typical applications are expanding tubular extensions and flaring tail-pipes, so one-piece can fit inside the other.



### Mechanical Joining

**No soldering, brazing or welding necessary**

Elliott is the industry leader in providing mechanical joining tools for joining metal tubes to fittings and flanges. Elliott mechanical joining tools are utilized extensively throughout the aerospace, hydraulics and automotive industries and in many industrial applications worldwide.

Because the mechanical joint will not leak, pull off or vibrate loose when properly installed, engineers who design hydraulic or pneumatic systems consider it superior to welded or brazed joints.

Practically every tubing material (except plastic or rubber) can be mechanically joined, provided the tube is annealed or is ductile. Common tube materials utilized by our customers are steel and aluminum. Copper, cupro-nickel, titanium, inconel and other high strength materials have been successfully joined to fittings by this cold rolling process. This process is good for the joining of a tube to any flange, casting or metal structure, such as a cup plug or valve seat, transmission return tubes and high pressure pneumatic and hydraulic fittings for aerospace.

Tubes with a 0.015" to .500" (0.38 to 13mm) wall thickness and a .250" to 12" (6 to 305mm) diameter have been cold rolled successfully with Elliott mechanical joining tools. The amount of compression required for an optimum joint varies with the tube material.

The mechanical joining tool consist of a cage, tapered mandrel and inversely tapered rolls, allowing for true parallel expansion. The tool can be controlled with a micrometer adjustment feature allowing the operator to set the tool to any tolerance required. The tool's expansion can also be controlled with the Elliott Torque Control system.

This tool can be fully automated in a complete system for producing mechanical joints. The tool can be driven by hand with a suitable wrench, air or electric drills, drill units or standard shop machines.

After the tool is inserted in the tube (Fig. 1), the rotating rolls force the tube wall into the machined grooves or serrations of the fitting (Figs. 2 and 3). Because the tube is mechanically joined into the fitting (Fig. 4), it cannot move as a result of temperature changes, internal pressures or vibration.

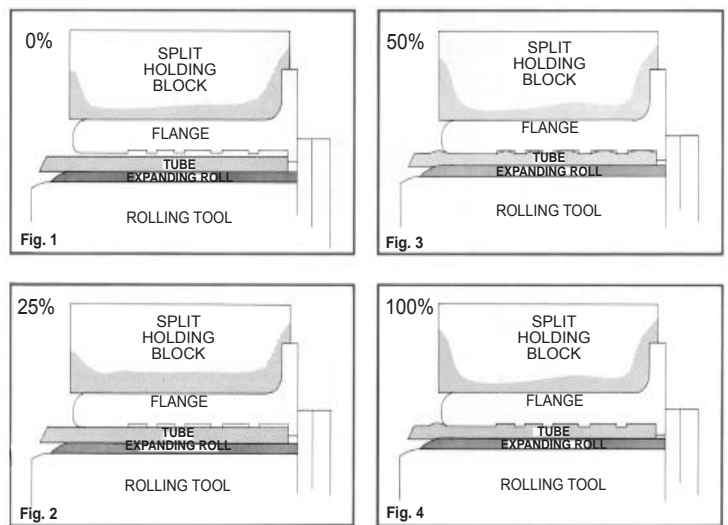

The above diagram shows the tube being swaged during four stages.

# BURNISHING TOOL DIMENSIONS

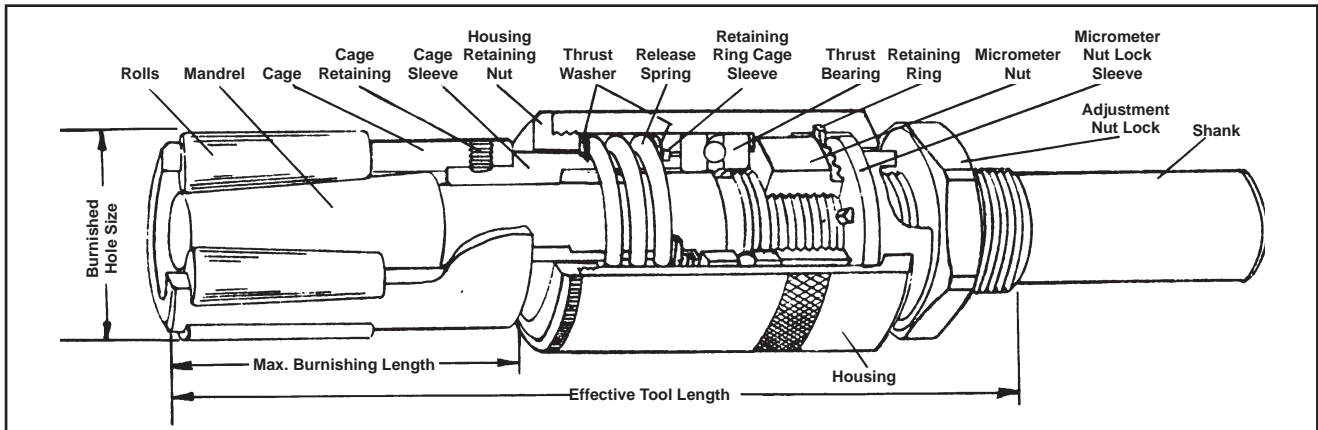

A Size Range	Tool Series	B Effective Tool Reach		C Max. Burnishing Reach				D Housing Dia.	E Drive Shank	
		Stub	Regular	Stub	Regular	Stub	Long		Straight	Morse Taper
.187 - .484	5418									
.500 - .625	5419	5-1/8	1-5/8	7-1/8	3-5/8	9-1/8	5-7/8	1-3/16	1/2 x 1-1/2	No. 1
.656 - .937	5433		1-5/8		3-5/8		5-5/8			
.968 - 1.187	5444	5-1/8	1-7/8	7-1/8	3-7/8	9-1/8	5-7/8	1-3/16	1/2 x 1-1/2	No. 1
1.218 - 1.375	5405	5-3/16						1-3/16	3/4 x 1-1/2	No. 2
1.406 - 1.812	5406									
1.843 - 2.187	5407									
2.218 - 2.687	5408	7-3/16						1-3/4	1 x 2-1/2	No. 3
2.718 - 3.312	5409									
3.343 - 4.062	5610									
4.093 - 5.000	5611	9-1/8						2-15/16	1-1/2 x 5	No. 4
5.031 - 5.875	5612									
5.906 - 6.500	5613									

HOUSING SMALLER THAN HOLE  
MAX. BURNISHING  
LENGTH CONTROLLED BY  
TOOL LENGTH OR  
SHANK EXTENSIONS.

Special tools with burnishing lengths longer than shown are available and will be quoted upon request. Special deep hole tools with bodies smaller than the cages are available from .375" to 1.187".

## Through Holes and Blind Holes

Tools with relieved rolls are used for through holes (Roll Style 1). These tools are self-feeding and a release clearance is required as described below. The through rolls cannot burnish as close to the bottom of the hole as blind end rolls (Roll Style 4). These rolls are interchangeable within the standard cages.

**Full Bottoming rolls** can be used in blind hole applications to minimize the release clearance (Roll Style 8). These rolls can be used in all standard cages.

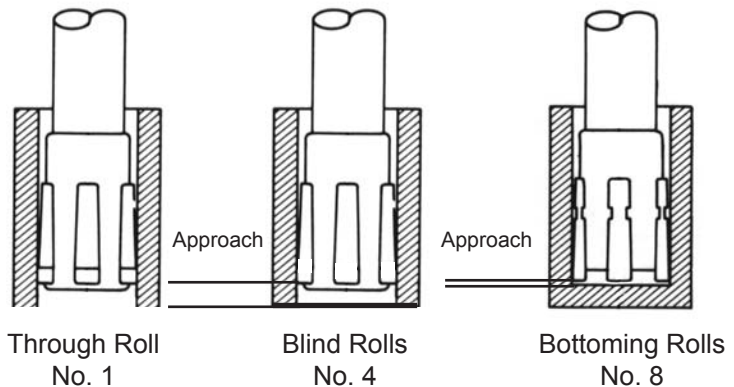

## APPROACH TO BOTTOM CHART

Tool Sizes	Standard Tool Through Rolls	Standard Tool Blind Rolls	Bottoming Tool Bottoming Rolls
.187 - .359	---	.093	---
.375 - .593	---	.093	.045
.625 - 1.093	.218	.125	.060
1.125 - 3.312	.375	.156	.060
3.343 - 6.500	.406	.187	.060

Approach includes a release clearance of .030" which may be subtracted to obtain absolute minimum approach.

## ORDERING PROCEDURE

**When ordering tools, refer to pages 13 through 27 for product numbers.**

- (1) Check the "Tool Size Range" column for the tool with the maximum adjustment above the burnishing diameter.
- (2) Choose the closest nominal diameter for the tool you require.
- (3) Select the 12-digit number for a standard or bottoming tool with the required shank.

**NOTE:** The 12-digit number for complete tools consists of three sets of numbers: The first four digits are the series number. The next three digits represent the shank, length and mandrel tip, respectively. The last set of five digits represents the style (the first two digits - through, blind or full bottoming) and the size (the last three digits) in 1/64" increments.

**For Series 5418 through 5444:** Please refer to the "Burnishing Reach" column for the depth the tool can reach. For example, a 1.000" standard tool, with 3" reach, straight shank is 5444-121-11064.

**For Series 5405 through 5612:** Burnishing Reach is not applicable.

For example: The number for a 1.500" standard tool, straight shank, through-style is: 5406-101-11096

- (4) When ordering tools with intermediate mandrel tips, change the seventh digit of the 12-digit number. For example, a complete tool with a 6 intermediate mandrel tip requires changing the "1" to a "6", so then 5404-101-11080 becomes 5404-106-11080 (see below).
- (5) To order spare parts, specify part numbers for each item required.  
For example: A cage sleeve for a 1.000" tool with 3" reach is 5304-072-20000.
- (6) When converting to a new tool size within the **same** series, choose new sizes per steps 1 and 2 above. Compare spare part numbers for the new size with those of the present size to determine conversion parts required. This also applies when converting from standard to bottoming tools in the same series.

## WHY AND HOW TO ORDER INTERMEDIATE TIPS

Ordering a burnishing tool with an intermediate mandrel tip allows close approach to the bottom of a blind end hole. It will allow tool adjustments above the nominal size without the mandrel tip extending past the end of the cage. Order intermediate tips by changing the seventh position of the 12-digit number selected. Looking at the example given below, a 6 tip is required. This tip would be ordered by changing the seventh digit from a "1" to a "6" so the tip number changes from 5305-031-00080 and becomes 5305-036-00080.

- (1) Maximum adjustment possible without tip extending past the end of the cage.
- (2) Select the highest intermediate tip size (or next larger size tool) that will enter the bore size.  
Example: 1.266 size of bore could use -4 (.008 - .016)  
1.250 nominal size -5 (.012 - .020)  
.016 diameter difference -6 (.016 - .024) use -6 intermediate tip.

## INTERMEDIATE MANDREL TIP SELECTION CHART

Standard through Tools (Style #11 and 31)			
For Tool Sizes	Adjustment Range with Intermediate Sizes (Above Nominal Size)		Intermediate Mandrel Tip Size (2)
	Min.	Max.(1)	
.187	(-.003)	.001	-1
	.000	.004	-2
	.003	.007	-3
.193	.003	.007	-3
	.006	.010	-4
	.009	.013	-5
	.012	.015	-6
.203 to .484	(-.003)	.001	-1
	.000	.001	-2
	.003	.007	-3
	.006	.010	-4
	.009	.013	-5
.500 and Larger	.012	.015	-6
	(-.004)	.004	-1
	.000	.008	-2
	.004	.012	-3
	.008	.016	-4
	.012	.020	-5
	.016	.024	-6
.020	.028	-7	
.024	.032	-8	

Full Bottoming Tools (Style #45)			
For Tool Sizes	Adjustment Range with Intermediate Sizes (Above Nominal Size)		Intermediate Mandrel Tip Size (2)
	Min.	Max.(1)	
FULL BOTTOMING TOOLS NOT STANDARD IN SIZES BELOW .250			
.250 to .484	(-.003)	(-.001)	-1
	.000	.001	-2
	.003	.007	-3
	.006	.010	-4
	.009	.013	-5
	.012	.015	-6
.500 and Larger	(-.004)	(-.001)	-1
	.000	.003	-2
	.004	.007	-3
	.008	.011	-4
	.012	.015	-5
	.016	.019	-6
	.020	.023	-7
	.024	.027	-8

COMPLETE TOOL											SPARE PARTS	
TOOL SERIES: 5418 RANGE: .187" TO .484"												
Tool Size Range	Tool Nominal Diameter	Maximum Burnishing Reach (Inches)			Standard Tool Number Style (31)		Full Bottoming Tool Number Style (45)		Cage Number			
					Straight Shank	Morse Taper Shank	Straight Shank	Morse Taper Shank	Standard	Full Bottoming		
.184 to .193	.187	1-5/8	3-5/8	5-5/8	5418-111-31012 -121- -131-	5418-211-31012 -221- -231-	Not available as standard below .250"	Not available as standard below .250"	5301-011-10012 -20012 -30012			
.190 to .203	.193	1-5/8	3-5/8	5-5/8	-111-31011 -121- -131-	-211-31011 -221- -231-			-10011 -20011 -30011			
.200 to .220	.203	1-5/8	3-5/8	5-5/8	-111-31013 -121- -131-	-211-31013 -221- -231-			-10013 -20013 -30013			
.215 to .235	.218	1-5/8	3-5/8	5-5/8	-111-31014 -121- -131-	-211-31014 -221- -231-			-10014 -20014 -30014			
.231 to .251	.234	1-5/8	3-5/8	5-5/8	-111-31015 -121- -131-	-211-31015 -221- -231-			-10015 -20015 -30015			
.247 to .267	.250	1-5/8	3-5/8	5-5/8	-111-31016 -121- -131-	-211-31016 -221- -231-	5418-112-45016 -122- -132-	5418-212-45016 -222- -232-	-10016 -20016 -30016			
.262 to .282	.265	1-5/8	3-5/8	5-5/8	-111-31017 -121- -131-	-211-31017 -221- -231-	-112-45017 -122- -132-	-212-45017 -222- -232-	-10017 -20017 -30017			
.278 to .298	.281	1-5/8	3-5/8	5-5/8	-111-31018 -121- -131-	-211-31018 -221- -231-	-112-45018 -122- -132-	-212-45018 -222- -232-	-10018 -20018 -30018			
.293 to .313	.296	1-5/8	3-5/8	5-5/8	-111-31019 -121- -131-	-211-31019 -221- -231-	-112-45019 -122- -132-	-212-45019 -222- -232-	-10019 -20019 -30019			
.309 to .329	.312	1-5/8	3-5/8	5-5/8	-111-31020 -121- -131-	-211-31020 -221- -231-	-112-45020 -122- -132-	-212-45020 -222- -232-	-10020 -20020 -30020			
.325 to .345	.328	1-5/8	3-5/8	5-5/8	-111-31021 -121- -131-	-211-31021 -221- -231-	-112-45021 -122- -132-	-212-45021 -222- -232-	-10021 -20021 -30021			
.340 to .360	.343	1-5/8	3-5/8	5-5/8	-111-31022 -121- -131-	-211-31022 -221- -231-	-112-45022 -122- -132-	-212-45022 -222- -232-	-10022 -20022 -30022			
.356 to .376	.359	1-5/8	3-5/8	5-5/8	-111-31023 -121- -131-	-211-31023 -221- -231-	-112-45023 -122- -132-	-212-45023 -222- -232-	-10023 -20023 -30023			
.372 to .392	.375	1-5/8	3-5/8	5-5/8	-111-31024 -121- -131-	-211-31024 -221- -231-	-112-45024 -122- -132-	-212-45024 -222- -232-	-10024 -20024 -30024			
.387 to .407	.390	1-5/8	3-5/8	5-5/8	-111-31025 -121- -131-	-211-31025 -221- -231-	-112-45025 -122- -132-	-212-45025 -222- -232-	-10025 -20025 -30025			
.403 to .423	.406	1-5/8	3-5/8	5-5/8	-111-31026 -121- -131-	-211-31026 -221- -231-	-112-45026 -122- -132-	-212-45026 -222- -232-	-10026 -20026 -30026			
.418 to .438	.421	1-5/8	3-5/8	5-5/8	-111-31027 -121- -131-	-211-31027 -221- -231-	-112-45027 -122- -132-	-212-45027 -222- -232-	-10027 -20027 -30027			
.434 to .454	.437	1-5/8	3-5/8	5-5/8	-111-31028 -121- -131-	-211-31028 -221- -231-	-112-45028 -122- -132-	-212-45028 -222- -232-	-10028 -20028 -30028			
.450 to .470	.453	1-5/8	3-5/8	5-5/8	-111-31029 -121- -131-	-211-31029 -221- -231-	-112-45029 -122- -132-	-212-45029 -222- -232-	-10029 -20029 -30029			
.465 to .485	.468	1-5/8	3-5/8	5-5/8	-111-31030 -121- -131-	-211-31030 -221- -231-	-112-45030 -122- -132-	-212-45030 -222- -232-	-10030 -20030 -30030			
.481 to .501	.484	1-5/8	3-5/8	5-5/8	-111-31031 -121- -131-	-211-31031 -221- -231-	-112-45031 -122- -132-	-212-45031 -222- -232-	-10031 -20031 -30031			

TOOL SERIES: 5419 RANGE: .500" TO .625"												
Tool Size Range	Tool Nominal Diameter	Maximum Burnishing Reach (Inches)			Standard Tool Number Thru Style (11)		Standard Tool Number Blind Style (31)		Full Bottoming Tool Number Style (45)		Cage Number	
					Straight Shank 5419-	Morse Taper Shank 5419-	Straight Shank 5419-	Morse Taper Shank 5419-	Straight Shank 5419-	Morse Taper Shank 5419-	Standard	Full Bottoming
.496 to .537	.500	1-7/8	3-7/8	5-7/8			-111-31032 -121- -131-	-211-31032 -221- -231-	-112-45032 -122- -132-	-212-45032 -222- -232-	5151-400-00500	5135-400-00500
.527 to .568	.531	1-7/8	3-7/8	5-7/8			-111-31034 -121- -131-	-211-31034 -221- -231-	-112-45034 -122- -132-	-212-45034 -222- -232-	-00531	-00531
.558 to .599	.562	1-7/8	3-7/8	5-7/8			-111-31036 -121- -131-	-211-31036 -221- -231-	-112-45036 -122- -132-	-212-45036 -222- -232-	-00562	-00562
.589 to .630	.593	1-7/8	3-7/8	5-7/8			-111-31038 -121- -131-	-211-31038 -221- -231-	-112-45038 -122- -132-	-212-45038 -222- -232-	-00593	-00593
.621 to .662	.625	1-7/8	3-7/8	5-7/8	-111-11040 -121- -131-	-211-11040 -221- -231-	-111-31040 -121- -131-	-211-31040 -221- -231-	-112-45040 -122- -132-	-212-45040 -222- -232-	-00625	-00625

SPARE PARTS											Shanks and Housings		
TOOL SERIES: 5418 RANGE: .187" TO .484"													
Tool Nominal Diameter	Cage Sleeve Number	Mandrel Tip Number		Size	ROLLS								
		Standard	Bottoming		Standard		Blind-Style		Full Bottoming				
					Number Per Set	Part Number	Number Per Set	Part Number	Roll Size	Number Per Set	Part Number		
.187	5401-071-00000	5418-031-10012 -20012 -30012	Not available below .250"	.062	5	5100-704-00062	5	5100-704-00062					
.193		5418-033-10012 -20012 -30012											
.203		5418-031-10013 -20013 -30013											
.218		-10013 -20013 -30013		.070	5	5100-704-00070	5	5100-704-00070					
.234		-10015 -20015 -30015											
.250		-10015 -20015 -30015	5418-032-10012 -20012 -30012		.078	5	5100-704-00078	5	5100-704-00078				
.265		-10017 -20017 -30017	-10013 -20013 -30013										
.281		-10017 -20017 -30017	-10015 -20015 -30015		.086	5	5100-704-00086	5	5100-704-00086				
.296		-10019 -20019 -30019	-10017 -20017 -30017										
.312		-10019 -20019 -30019	-10019 -20019 -30019		.093	5	5100-704-00093	5	5100-704-00093	.093	3	5100-708-00093	
.328		-10021 -20021 -30021	-10021 -20021 -30021										
.343		-10019 -20019 -30019	-10019 -20019 -30019		.109	5	5100-704-00109	5	5100-704-00109		3	5100-708-00109	
.359		-10021 -20021 -30021	-10021 -20021 -30021										
.375		5318-031-10024 -20024 -30024	5418-032-10019 -20019 -30019		.125	5	5100-704-00125	5	5100-704-00125		3	5100-708-00125	
.390		-10025 -20025 -30025	-10021 -20021 -30021										
.406		-10024 -20024 -30024	5318-032-10024 -20024 -30024		.125	5	5100-704-00125	5	5100-704-00125		3	5100-708-00125	
.421		-10025 -20025 -30025	-10025 -20025 -30025										
.437		-10028 -20028 -30028	-10028 -20028 -30028		.148	5	5100-704-00148	5	5100-704-00148		3	5100-708-00156	
.453	-10024 -20024 -30024	5418-032-10021 -20021 -30021											
.468	-10025 -20025 -30025	5318-032-10024 -20024 -30024											
.484	-10028 -20028 -30028	-10025 -20025 -30025											

No. 1 Morse Taper Shank 5333-042-10000

Housing Assembly 5401-182-00000

Straight Shank 5333-041-10000

TOOL SERIES: 5419 RANGE: .500" TO .625"										
Tool Nominal Diameter	Cage Sleeve Number	Mandrel Tip Number		Size	ROLLS					
		Standard	Bottoming		Standard		Blind-Style		Full Bottoming	
					Number Per Set	Part Number	Number Per Set	Part Number	Number Per Set	Part Number
.500	5319-077-10000 -20000 -30000	5319-031-10032 -20032 -30032	5319-032-10032 -20032 -30032	.156	5	5100-704-00156	5	5100-704-00156	5	5100-708-00156
.531	5319-078-10000 -20000 -30000	-10034 -20034 -30034	-10034 -20034 -30034							
.562	-10000 -20000 -30000	-10034 -20034 -30034	-10034 -20034 -30034	.172	5	5100-704-00172	5	5100-704-00172	5	5100-708-00172
.593	5319-079-10000 -20000 -30000	-10038 -20038 -30038	-10038 -20038 -30038							
.625	-10000 -20000 -30000	-10038 -20038 -30038	-10038 -20038 -30038	.187	5	5100-701-00187	5	5100-704-00187	5	5100-708-00187

COMPLETE TOOL												SPARE PARTS	
TOOL SERIES: 5433 RANGE: .656" TO .937"												Cage Number	
Tool Size Range	Tool Nominal Diameter	Maximum Burnishing Reach (Inches)		Standard Tool Number Thru Style (11)		Standard Tool Number Blind Style (31)		Full Bottoming Tool Number Style (45)		Standard	Full Bottoming		
				Straight Shank 5433-	Morse Taper Shank 5433-	Straight Shank 5433-	Morse Taper Shank 5433-	Straight Shank 5433-	Morse Taper Shank 5433-				
.652 to .693	0.656	1-5/8	3-5/8	5-5/8	-111-11042 -121- -131-	-211-11042 -221- -231-	-111-31042 -121- -131-	-211-31042 -221- -231-	-112-45042 -122- -132-	-212-45042 -222- -232-	5403-011-00042	5403-015-00042	
.683 to .724	0.687	1-5/8	3-5/8	5-5/8	-111-11044 -121- -131-	-211-11044 -221- -231-	-111-31044 -121- -131-	-211-31044 -221- -231-	-112-45044 -122- -132-	-212-45044 -222- -232-	-00044	-00044	
.714 to .755	0.718	1-5/8	3-5/8	5-5/8	-111-11046 -121- -131-	-211-11046 -221- -231-	-111-31046 -121- -131-	-211-31046 -221- -231-	-112-45046 -122- -132-	-212-45046 -222- -232-	-00046	-00046	
.746 to .787	0.750	1-5/8	3-5/8	5-5/8	-111-11048 -121- -131-	-211-11048 -221- -231-	-111-31048 -121- -131-	-211-31048 -221- -231-	-112-45048 -122- -132-	-212-45048 -222- -232-	-00048	-00048	
.777 to .818	0.781	1-5/8	3-5/8	5-5/8	-111-11050 -121- -131-	-211-11050 -221- -231-	-111-31050 -121- -131-	-211-31050 -221- -231-	-112-45050 -122- -132-	-212-45050 -222- -232-	-00050	-00050	
.808 to .849	0.812	1-5/8	3-5/8	5-5/8	-111-11052 -121- -131-	-211-11052 -221- -231-	-111-31052 -121- -131-	-211-31052 -221- -231-	-112-45052 -122- -132-	-212-45052 -222- -232-	-00052	-00052	
.839 to .880	0.843	1-5/8	3-5/8	5-5/8	-111-11054 -121- -131-	-211-11054 -221- -231-	-111-31054 -121- -131-	-211-31054 -221- -231-	-112-45054 -122- -132-	-212-45054 -222- -232-	-00054	-00054	
.871 to .912	0.875	1-5/8	3-5/8	5-5/8	-111-11056 -121- -131-	-211-11056 -221- -231-	-111-31056 -121- -131-	-211-31056 -221- -231-	-112-45056 -122- -132-	-212-45056 -222- -232-	-00056	-00056	
.902 to .943	0.906	1-5/8	3-5/8	5-5/8	-111-11058 -121- -131-	-211-11058 -221- -231-	-111-31058 -121- -131-	-211-31058 -221- -231-	-112-45058 -122- -132-	-212-45058 -222- -232-	-00058	-00058	
.933 to .974	0.937	1-5/8	3-5/8	5-5/8	-111-11060 -121- -131-	-211-11060 -221- -231-	-111-31060 -121- -131-	-211-31060 -221- -231-	-112-45060 -122- -132-	-212-45060 -222- -232-	-00060	-00060	

TOOL SERIES: 5444 RANGE: .968" TO 1.187"												Cage Number	
Tool Size Range	Tool Nominal Diameter	Maximum Burnishing Reach (Inches)		Standard Tool Number Thru Style (11)		Standard Tool Number Blind Style (31)		Full Bottoming Tool Number Style (45)		Standard	Full Bottoming		
				Straight Shank 5444-	Morse Taper Shank 5444-	Straight Shank 5444-	Morse Taper Shank 5444-	Straight Shank 5444-	Morse Taper Shank 5444-				
.964 to 1.005	0.968	1-7/8	3-7/8	5-7/8	-111-11062 -121- -131-	-211-11062 -221- -231-	-111-31062 -121- -131-	-211-31062 -221- -231-	-112-45062 -122- -132-	-212-45062 -222- -232-	5404-011-00062	5404-015-00062	
.996 to 1.037	1.000	1-7/8	3-7/8	5-7/8	-111-11064 -121- -131-	-211-11064 -221- -231-	-111-31064 -121- -131-	-211-31064 -221- -231-	-112-45064 -122- -132-	-212-45064 -222- -232-	-00064	-00064	
1.027 to 1.068	1.031	1-7/8	3-7/8	5-7/8	-111-11066 -121- -131-	-211-11066 -221- -231-	-111-31066 -121- -131-	-211-31066 -221- -231-	-112-45066 -122- -132-	-212-45066 -222- -232-	-00066	-00066	
1.058 to 1.099	1.062	1-7/8	3-7/8	5-7/8	-111-11068 -121- -131-	-211-11068 -221- -231-	-111-31068 -121- -131-	-211-31068 -221- -231-	-112-45068 -122- -132-	-212-45068 -222- -232-	-00068	-00068	
1.089 to 1.130	1.093	1-7/8	3-7/8	5-7/8	-111-11070 -121- -131-	-211-11070 -221- -231-	-111-31070 -121- -131-	-211-31070 -221- -231-	-112-45070 -122- -132-	-212-45070 -222- -232-	-00070	-00070	
1.121 to 1.162	1.125	1-7/8	3-7/8	5-7/8	-111-11072 -121- -131-	-211-11072 -221- -231-	-111-31072 -121- -131-	-211-31072 -221- -231-	-112-45072 -122- -132-	-212-45072 -222- -232-	-00072	-00072	
1.152 to 1.193	1.156	1-7/8	3-7/8	5-7/8	-111-11074 -121- -131-	-211-11074 -221- -231-	-111-31074 -121- -131-	-211-31074 -221- -231-	-112-45074 -122- -132-	-212-45074 -222- -232-	-00074	-00074	
1.183 to 1.224	1.187	1-7/8	3-7/8	5-7/8	-111-11076 -121- -131-	-211-11076 -221- -231-	-111-31076 -121- -131-	-211-31076 -221- -231-	-112-45076 -122- -132-	-212-45076 -222- -232-	-00076	-00076	

TOOL SERIES: 5405 RANGE: 1.218" TO 1.375"												Cage Number	
Tool Size Range	Tool Nominal Diameter	Standard Tool Number Thru Style (11)		Standard Tool Number Blind Style (31)		Full Bottoming Tool Number Style (45)		Standard	Full Bottoming				
		Straight Shank 5405-	Morse Taper Shank 5405-	Straight Shank 5405-	Morse Taper Shank 5405-	Straight Shank 5405-	Morse Taper Shank 5405-						
1.214 to 1.255	1.218	-101-11078	-201-11078	-101-31078	-201-31078	-102-45078	-202-45078	5405-011-00078	5405-015-00078				
1.246 to 1.287	1.250	-11080	-11080	-31080	-31080	-45080	-45080	-00080	-00080				
1.277 to 1.318	1.281	-11082	-11082	-31082	-31082	-45082	-45082	-00082	-00082				
1.308 to 1.349	1.312	-11084	-11084	-31084	-31084	-45084	-45084	-00084	-00084				
1.339 to 1.380	1.343	-11086	-11086	-31086	-31086	-45086	-45086	-00086	-00086				
1.371 to 1.412	1.375	-11088	-11088	-31088	-31088	-45088	-45088	-00088	-00088				

SPARE PARTS											Shanks and Housings		
TOOL SERIES: 5433* RANGE: .656" TO .937"											Reach		
Tool Nominal Diameter	Cage Sleeve Number	Mandrel Tip Number		Size	ROLLS						1-5/8"	3-5/8"	5-5/8"
		Standard	Bottoming		Standard		Blind-Style		Full Bottoming				
					Number Per Set	Part Number	Number Per Set	Part Number	Number Per Set	Part Number			
.656	5333-072-10000 -20000 -30000 -10000	5333-031-00042	5333-032-00042	.187	5	5100-701-00187	5	5100-704-00187	5	5100-708-00187	No. 1 Morse Taper Shank 5333-042-10000	No. 1 Morse Taper Shank 5333-042-20000	No. 1 Morse Taper Shank 5333-042-30000
.687	-20000 -30000	-00044	-00044										
.718	-10000 -20000 -30000	-00042	-00042										
.750	-10000 -20000 -30000	-00044	-00044										
.781	-10000 -20000 -30000	-00050	-00050	.218	5	5100-701-00218	5	5100-704-00218	5	5100-708-00218			
.812	-10000 -20000 -30000	-00052	-00052										
.843	-10000 -20000 -30000	-00054	-00054										
.875	-10000 -20000 -30000	-00050	-00050										
.906	-10000 -20000 -30000	-00052	-00052	.265	5	5100-701-00265	5	5100-704-00265	5	5100-708-00265			
.937	-10000 -20000 -30000	-00054	-00054										

TOOL SERIES: 5444* RANGE: .968" TO 1.187"											Reach		
Tool Nominal Diameter	Cage Sleeve Number	Mandrel Tip Number		Size	ROLLS						1-5/8"	3-5/8"	5-5/8"
		Standard	Bottoming		Standard		Blind-Style		Full Bottoming				
					Number Per Set	Part Number	Number Per Set	Part Number	Number Per Set	Part Number			
.968	5304-072-10000 -20000 -30000	5344-031-00062	5344-032-00062	.265	5	5100-701-00265	5	5100-704-00265	5	5100-708-00265	Straight Shank 5333-041-10000	Straight Shank 5333-041-20000	Straight Shank 5333-041-30000
1.000	-10000 -20000 -30000	-00064	-00064										
1.031	-10000 -20000 -30000	-00066	-00066										
1.062	-10000 -20000 -30000	-00068	-00068	.265	7	5100-701-00265	7	5100-704-00265	5	5100-708-00265			
1.093	-10000 -20000 -30000	-00070	-00070										
1.125	-10000 -20000 -30000	-00066	-00066										
1.156	-10000 -20000 -30000	-00068	-00068	.312	7	5100-701-00312	7	5100-704-00312	5	5100-708-00312			
1.187	-10000 -20000 -30000	-00070	-00070										

TOOL SERIES: 5405 RANGE: 1.218" TO 1.375"											Reach		
Tool Nominal Diameter	Cage Sleeve Number	Mandrel Tip Number		Size	ROLLS						1-5/8"	3-5/8"	5-5/8"
		Standard	Bottoming		Standard		Blind-Style		Full Bottoming				
					Number Per Set	Part Number	Number Per Set	Part Number	Number Per Set	Part Number			
1.218	5305-073-00000	5305-031-00078	5305-032-00078	.265	7	5100-701-00265	7	5100-704-00265	5	5100-708-00265	5405-041-00000	5405-042-00000	5433-182-00000
1.250		-00080	-00080										
1.281		-00082	-00082										
1.312		-00078	-00078										
1.343		-00080	-00080	.312	7	5100-701-00312	7	5100-704-00312	5	5100-708-00312			
1.375		-00082	-00082										

\*Tool Series 5433 & 5444: to change burnishing length, it is necessary to change the cage sleeve and mandrel shank.

COMPLETE TOOL								SPARE PARTS	
TOOL SERIES: 5406 RANGE: 1.406" TO 1.812"								Cage Number	
Tool Size Range	Tool Nominal Diameter	Standard Tool Number Thru Style (11)		Standard Tool Number Blind Style (31)		Full Bottoming Tool Number Style (45)			
		Straight Shank 5406-	Morse Taper Shank 5406-	Straight Shank 5406-	Morse Taper Shank 5406-	Straight Shank 5406-	Morse Taper Shank 5406-	Standard	Full Bottoming
1.402 to 1.443	1.406	-101-11090	-201-11090	-101-31090	-201-31090	-102-45090	-202-45090	5406-011-00090	5406-015-00090
1.433 to 1.474	1.437	-11092	-11092	-31092	-31092	-45092	-45092	-00092	-00092
1.464 to 1.505	1.468	-11094	-11094	-31094	-31094	-45094	-45094	-00094	-00094
1.496 to 1.537	1.500	-11096	-11096	-31096	-31096	-45096	-45096	-00096	-00096
1.527 to 1.568	1.531	-11098	-11098	-31098	-31098	-45098	-45098	-00098	-00098
1.558 to 1.599	1.562	-11100	-11100	-31100	-31100	-45100	-45100	-00100	-00100
1.589 to 1.630	1.593	-11102	-11102	-31102	-31102	-45102	-45102	-00102	-00102
1.621 to 1.662	1.625	-11104	-11104	-31104	-31104	-45104	-45104	-00104	-00104
1.652 to 1.693	1.656	-11106	-11106	-31106	-31106	-45106	-45106	-00106	-00106
1.683 to 1.724	1.687	-11108	-11108	-31108	-31108	-45108	-45108	-00108	-00108
1.714 to 1.755	1.718	-11110	-11110	-31110	-31110	-45110	-45110	-00110	-00110
1.746 to 1.787	1.750	-11112	-11112	-31112	-31112	-45112	-45112	-00112	-00112
1.777 to 1.818	1.781	-11114	-11114	-31114	-31114	-45114	-45114	-00114	-00114
1.808 to 1.849	1.812	-11116	-11116	-31116	-31116	-45116	-45116	-00116	-00116

TOOL SERIES: 5407 RANGE: 1.843" TO 2.187"								Cage Number	
Tool Size Range	Tool Nominal Diameter	Standard Tool Number Thru Style (11)		Standard Tool Number Blind Style (31)		Full Bottoming Tool Number Style (45)			
		Straight Shank 5407-	Morse Taper Shank 5407-	Straight Shank 5407-	Morse Taper Shank 5407-	Straight Shank 5407-	Morse Taper Shank 5407-	Standard	Full Bottoming
1.839 to 1.880	1.843	-101-11118	-201-11118	-101-31118	-201-31118	-102-45118	-202-45118	5407-011-00118	5407-015-00118
1.871 to 1.912	1.875	-11120	-11120	-31120	-31120	-45120	-45120	-00120	-00120
1.902 to 1.943	1.906	-11122	-11122	-31122	-31122	-45122	-45122	-00122	-00122
1.934 to 1.974	1.937	-11124	-11124	-31124	-31124	-45124	-45124	-00124	-00124
1.964 to 2.005	1.968	-11126	-11126	-31126	-31126	-45126	-45126	-00126	-00126
1.996 to 2.037	2.000	-11128	-11128	-31128	-31128	-45128	-45128	-00128	-00128
2.027 to 2.068	2.031	-11130	-11130	-31130	-31130	-45130	-45130	-00130	-00130
2.058 to 2.099	2.062	-11132	-11132	-31132	-31132	-45132	-45132	-00132	-00132
2.089 to 2.130	2.093	-11134	-11134	-31134	-31134	-45134	-45134	-00134	-00134
2.121 to 2.162	2.125	-11136	-11136	-31136	-31136	-45136	-45136	-00136	-00136
2.152 to 2.193	2.156	-11138	-11138	-31138	-31138	-45138	-45138	-00138	-00138
2.183 to 2.224	2.187	-11140	-11140	-31140	-31140	-45140	-45140	-00140	-00140

TOOL SERIES: 5408 RANGE: 2.218" TO 2.687"								Cage Number	
Tool Size Range	Tool Nominal Diameter	Standard Tool Number Thru Style (11)		Standard Tool Number Blind Style (31)		Full Bottoming Tool Number Style (45)			
		Straight Shank 5408-	Morse Taper Shank 5408-	Straight Shank 5408-	Morse Taper Shank 5408-	Straight Shank 5408-	Morse Taper Shank 5408-	Standard	Full Bottoming
2.214 to 2.255	2.218	-101-11142	-201-11142	-101-31142	-201-31142	-102-45142	-202-45142	5408-011-00142	5408-015-00142
2.246 to 2.287	2.250	-11144	-11144	-31144	-31144	-45144	-45144	-00144	-00144
2.277 to 2.318	2.281	-11146	-11146	-31146	-31146	-45146	-45146	-00146	-00146
2.308 to 2.349	2.312	-11148	-11148	-31148	-31148	-45148	-45148	-00148	-00148
2.339 to 2.380	2.343	-11150	-11150	-31150	-31150	-45150	-45150	-00150	-00150
2.371 to 2.412	2.375	-11152	-11152	-31152	-31152	-45152	-45152	-00152	-00152
2.402 to 2.443	2.406	-11154	-11154	-31154	-31154	-45154	-45154	-00154	-00154
2.433 to 2.474	2.437	-11156	-11156	-31156	-31156	-45156	-45156	-00156	-00156
2.464 to 2.505	2.468	-11158	-11158	-31158	-31158	-45158	-45158	-00158	-00158
2.496 to 2.537	2.500	-11160	-11160	-31160	-31160	-45160	-45160	-00160	-00160
2.527 to 2.568	2.531	-11162	-11162	-31162	-31162	-45162	-45162	-00162	-00162
2.558 to 2.599	2.562	-11164	-11164	-31164	-31164	-45164	-45164	-00164	-00164
2.589 to 2.630	2.593	-11166	-11166	-31166	-31166	-45166	-45166	-00166	-00166
2.621 to 2.662	2.625	-11168	-11168	-31168	-31168	-45168	-45168	-00168	-00168
2.652 to 2.693	2.656	-11170	-11170	-31170	-31170	-45170	-45170	-00170	-00170
2.683 to 2.724	2.687	-11172	-11172	-31172	-31172	-45172	-45172	-00172	-00172

TOOL SERIES: 5409 RANGE: 2.718" TO 3.312"								Cage Number	
Tool Size Range	Tool Nominal Diameter	Standard Tool Number Thru Style (11)		Standard Tool Number Blind Style (31)		Full Bottoming Tool Number Style (45)			
		Straight Shank 5409-	Morse Taper Shank 5409-	Straight Shank 5409-	Morse Taper Shank 5409-	Straight Shank 5409-	Morse Taper Shank 5409-	Standard	Full Bottoming
2.714 to 2.755	2.718	-101-11174	-201-11174	-101-31174	-201-31174	-102-45174	-202-45174	5409-011-00174	5409-015-00174
2.746 to 2.787	2.750	-11176	-11176	-31176	-31176	-45176	-45176	-00176	-00176
2.777 to 2.818	2.781	-11178	-11178	-31178	-31178	-45178	-45178	-00178	-00178
2.808 to 2.849	2.812	-11180	-11180	-31180	-31180	-45180	-45180	-00180	-00180
2.839 to 2.880	2.843	-11182	-11182	-31182	-31182	-45182	-45182	-00182	-00182
2.871 to 2.912	2.875	-11184	-11184	-31184	-31184	-45184	-45184	-00184	-00184
2.902 to 2.943	2.906	-11186	-11186	-31186	-31186	-45186	-45186	-00186	-00186
2.933 to 2.974	2.937	-11188	-11188	-31188	-31188	-45188	-45188	-00188	-00188
2.964 to 3.005	2.968	-11190	-11190	-31190	-31190	-45190	-45190	-00190	-00190
2.996 to 3.037	3.000	-11192	-11192	-31192	-31192	-45192	-45192	-00192	-00192
3.027 to 3.068	3.031	-11194	-11194	-31194	-31194	-45194	-45194	-00194	-00194
3.058 to 3.099	3.062	-11196	-11196	-31196	-31196	-45196	-45196	-00196	-00196
3.089 to 3.130	3.093	-11198	-11198	-31198	-31198	-45198	-45198	-00198	-00198
3.121 to 3.162	3.125	-11200	-11200	-31200	-31200	-45200	-45200	-00200	-00200
3.152 to 3.193	3.156	-11202	-11202	-31202	-31202	-45202	-45202	-00202	-00202
3.183 to 3.224	3.187	-11204	-11204	-31204	-31204	-45204	-45204	-00204	-00204
3.214 to 3.255	3.218	-11206	-11206	-31206	-31206	-45206	-45206	-00206	-00206
3.246 to 3.287	3.250	-11208	-11208	-31208	-31208	-45208	-45208	-00208	-00208
3.277 to 3.318	3.281	-11210	-11210	-31210	-31210	-45210	-45210	-00210	-00210
3.308 to 3.349	3.312	-11212	-11212	-31212	-31212	-45212	-45212	-00212	-00212

Burnishing Length: UNLIMITED (Tool body can pass thru bore).

SPARE PARTS										Shanks and Housings		
TOOL SERIES: 5406 RANGE: 1.406" TO 1.812"										Straight Shank 5405-041-00000	No. 2 MT 5405-042-00000	Housing Assembly 5433-182-00000
Tool Nominal Diameter	Cage Sleeve Number	Mandrel Tip Number		Size	ROLLS							
		Standard	Bottoming		Standard		Blind-Style		Full Bottoming			
					Number Per Set	Part Number	Number Per Set	Part Number	Number Per Set	Part Number		
1.406	5306-073-00000	5306-031-00090	5306-032-00090	.312	7	5100-701-00312	7	5100-704-00312	5	5100-708-00312		
1.437		-00092	-00092									
1.468		-00094	-00094									
1.500		-00096	-00096									
1.531		5305-031-00080	-00080	.406	7	5100-701-00406	7	5100-704-00406	5	5100-708-00406		
1.562		-00082	-00082									
1.593		5306-031-00090	-00090									
1.625		-00092	-00092									
1.656		-00094	-00094	.468	7	5100-701-00468	7	5100-704-00468	5	5100-708-00468		
1.687		5305-031-00082	-00082									
1.718		5306-031-00090	-00090									
1.750		-00092	-00092									
1.781	-00094	-00094	-00096	-00096								
1.812	-00096	-00096										

TOOL SERIES: 5407 RANGE: 1.843" TO 2.187"										Straight Shank 5407-041-00000	No. 3 MT 5407-042-00000	Housing Assembly 5407-182-00000
Tool Nominal Diameter	Cage Sleeve Number	Mandrel Tip Number		Size	ROLLS							
		Standard	Bottoming		Standard		Blind-Style		Full Bottoming			
					Number Per Set	Part Number	Number Per Set	Part Number	Number Per Set	Part Number		
1.843	5307-073-00000	5307-031-00118	5307-032-00118	.312	9	5100-701-00312	9	5100-704-00312	7	5100-708-00312		
1.875		-00120	-00120									
1.906		-00122	-00122									
1.937		-00124	-00124									
1.968		-00126	-00126	.406	9	5100-701-00406	9	5100-704-00406	7	5100-708-00406		
2.000		-00128	-00128									
2.031		-00118	-00118									
2.062		-00120	-00120									
2.093		-00122	-00122	-00124	-00124							
2.125		-00124	-00124									
2.156		-00126	-00126	-00128	-00128							
2.187		-00128	-00128									

TOOL SERIES: 5408 RANGE: 2.218" TO 2.687"										Straight Shank 5407-041-00000	No. 3 MT 5407-042-00000	Housing Assembly 5407-182-00000
Tool Nominal Diameter	Cage Sleeve Number	Mandrel Tip Number		Size	ROLLS							
		Standard	Bottoming		Standard		Blind-Style		Full Bottoming			
					Number Per Set	Part Number	Number Per Set	Part Number	Number Per Set	Part Number		
2.218	5308-073-00000	5308-031-00142	5308-032-00142	.406	9	5100-701-00406	9	5100-704-00406	7	5100-708-00406		
2.250		-00144	-00144									
2.281		-00146	-00146									
2.312		-00148	-00148									
2.343		-00142	-00142	.468	9	5100-701-00468	9	5100-704-00468	7	5100-708-00468		
2.375		-00144	-00144									
2.406		-00146	-00146									
2.437		-00148	-00148									
2.468		-00158	-00158	.531	9	5100-701-00531	9	5100-704-00531	7	5100-708-00531		
2.500		-00160	-00160									
2.531		-00162	-00162									
2.562		-00164	-00164									
2.593	-00158	-00158	-00160	-00160								
2.625	-00160	-00160										
2.656	-00162	-00162	-00164	-00164								
2.687	-00164	-00164										

TOOL SERIES: 5409 RANGE: 2.718" TO 3.312"										Straight Shank 5407-041-00000	No. 3 MT 5407-042-00000	Housing Assembly 5407-182-00000
Tool Nominal Diameter	Cage Sleeve Number	Mandrel Tip Number		Size	ROLLS							
		Standard	Bottoming		Standard		Blind-Style		Full Bottoming			
					Number Per Set	Part Number	Number Per Set	Part Number	Number Per Set	Part Number		
2.718	5309-073-00000	5309-031-00174	5309-032-00174	.531	9	5100-701-00531	9	5100-704-00531	7	5100-708-00531		
2.750		-00176	-00176									
2.781		-00178	-00178									
2.812		-00180	-00180									
2.843		-00182	-00182	.625	9	5100-701-00625	9	5100-704-00625	7	5100-708-00625		
2.875		-00184	-00184									
2.906		-00174	-00174									
2.937		-00176	-00176									
2.968		-00178	-00178	.687	9	5100-701-00687	9	5100-704-00687	7	5100-708-00687		
3.000		-00180	-00180									
3.031		-00182	-00182									
3.062		-00184	-00184									
3.093	-00198	-00198	-00200	-00200								
3.125	-00200	-00200										
3.156	-00202	-00202	-00204	-00204								
3.187	-00204	-00204										
3.218	-00198	-00198	-00200	-00200								
3.250	-00200	-00200										
3.281	-00202	-00202	-00204	-00204								
3.312	-00204	-00204										

Burnishing Length: UNLIMITED (Tool body can pass thru bore).

COMPLETE TOOL								SPARE PARTS	
TOOL SERIES: 5610 RANGE: 3.343" TO 4.062"								Cage Number	
Tool Size Range	Tool Nominal Diameter	Standard Tool Number Thru Style (11)		Standard Tool Number Blind Style (31)		Full Bottoming Tool Number Style (45)		Standard	Full Bottoming
		Straight Shank 5610-	Morse Taper Shank 5610-	Straight Shank 5610-	Morse Taper Shank 5610-	Straight Shank 5610-	Morse Taper Shank 5610-		
3.339 to 3.380	3.343	-101-11214	-201-11214	-101-31214	-201-31214	-102-45214	-202-45214	5610-011-00214	5610-015-00214
3.371 to 3.412	3.375	-11216	-11216	-31216	-31216	-45216	-45216	-00216	-00216
3.402 to 3.443	3.406	-11218	-11218	-31218	-31218	-45218	-45218	-00218	-00218
3.433 to 3.474	3.437	-11220	-11220	-31220	-31220	-45220	-45220	-00220	-00220
3.464 to 3.505	3.468	-11222	-11222	-31222	-31222	-45222	-45222	-00222	-00222
3.496 to 3.537	3.500	-11224	-11224	-31224	-31224	-45224	-45224	-00224	-00224
3.527 to 3.568	3.531	-11226	-11226	-31226	-31226	-45226	-45226	-00226	-00226
3.558 to 3.599	3.562	-11228	-11228	-31228	-31228	-45228	-45228	-00228	-00228
3.589 to 3.630	3.593	-11230	-11230	-31230	-31230	-45230	-45230	-00230	-00230
3.621 to 3.662	3.625	-11232	-11232	-31232	-31232	-45232	-45232	-00232	-00232
3.652 to 3.693	3.656	-11234	-11234	-31234	-31234	-45234	-45234	-00234	-00234
3.683 to 3.724	3.687	-11236	-11236	-31236	-31236	-45236	-45236	-00236	-00236
3.714 to 3.755	3.718	-11238	-11238	-31238	-31238	-45238	-45238	-00238	-00238
3.746 to 3.787	3.750	-11240	-11240	-31240	-31240	-45240	-45240	-00240	-00240
3.777 to 3.818	3.781	-11242	-11242	-31242	-31242	-45242	-45242	-00242	-00242
3.808 to 3.849	3.812	-11244	-11244	-31244	-31244	-45244	-45244	-00244	-00244
3.839 to 3.880	3.843	-11246	-11246	-31246	-31246	-45246	-45246	-00246	-00246
3.871 to 3.912	3.875	-11248	-11248	-31248	-31248	-45248	-45248	-00248	-00248
3.902 to 3.943	3.906	-11250	-11250	-31250	-31250	-45250	-45250	-00250	-00250
3.933 to 3.974	3.937	-11252	-11252	-31252	-31252	-45252	-45252	-00252	-00252
3.964 to 4.005	3.968	-11254	-11254	-31254	-31254	-45254	-45254	-00254	-00254
3.996 to 4.037	4.000	-11256	-11256	-31256	-31256	-45256	-45256	-00256	-00256
4.027 to 4.068	4.031	-11258	-11258	-31258	-31258	-45258	-45258	-00258	-00258
4.058 to 4.099	4.062	-11260	-11260	-31260	-31260	-45260	-45260	-00260	-00260

TOOL SERIES: 5611 RANGE: 4.093" TO 5.000"								Cage Number	
Tool Size Range	Tool Nominal Diameter	Standard Tool Number Thru Style (11)		Standard Tool Number Blind Style (31)		Full Bottoming Tool Number Style (45)		Standard	Full Bottoming
		Straight Shank 5611-	Morse Taper Shank 5611-	Straight Shank 5611-	Morse Taper Shank 5611-	Straight Shank 5611-	Morse Taper Shank 5611-		
4.089 to 4.130	4.093	-101-11262	-201-11262	-101-31262	-201-31262	-102-45262	-202-45262	5611-011-00262	5611-015-00262
4.121 to 4.162	4.125	-11264	-11264	-31264	-31264	-45264	-45264	-00264	-00264
4.152 to 4.193	4.156	-11266	-11266	-31266	-31266	-45266	-45266	-00266	-00266
4.183 to 4.224	4.187	-11268	-11268	-31268	-31268	-45268	-45268	-00268	-00268
4.214 to 4.255	4.218	-11270	-11270	-31270	-31270	-45270	-45270	-00270	-00270
4.246 to 4.287	4.250	-11272	-11272	-31272	-31272	-45272	-45272	-00272	-00272
4.277 to 4.318	4.281	-11274	-11274	-31274	-31274	-45274	-45274	-00274	-00274
4.308 to 4.349	4.312	-11276	-11276	-31276	-31276	-45276	-45276	-00276	-00276
4.339 to 4.380	4.343	-11278	-11278	-31278	-31278	-45278	-45278	-00278	-00278
4.371 to 4.412	4.375	-11280	-11280	-31280	-31280	-45280	-45280	-00280	-00280
4.402 to 4.443	4.406	-11282	-11282	-31282	-31282	-45282	-45282	-00282	-00282
4.433 to 4.474	4.437	-11284	-11284	-31284	-31284	-45284	-45284	-00284	-00284
4.464 to 4.505	4.468	-11286	-11286	-31286	-31286	-45286	-45286	-00286	-00286
4.496 to 4.537	4.500	-11288	-11288	-31288	-31288	-45288	-45288	-00288	-00288
4.527 to 4.568	4.531	-11290	-11290	-31290	-31290	-45290	-45290	-00290	-00290
4.558 to 4.599	4.562	-11292	-11292	-31292	-31292	-45292	-45292	-00292	-00292
4.589 to 4.630	4.593	-11294	-11294	-31294	-31294	-45294	-45294	-00294	-00294
4.621 to 4.662	4.625	-11296	-11296	-31296	-31296	-45296	-45296	-00296	-00296
4.652 to 4.693	4.656	-11298	-11298	-31298	-31298	-45298	-45298	-00298	-00298
4.683 to 4.724	4.687	-11300	-11300	-31300	-31300	-45300	-45300	-00300	-00300
4.714 to 4.755	4.718	-11302	-11302	-31302	-31302	-45302	-45302	-00302	-00302
4.746 to 4.787	4.750	-11304	-11304	-31304	-31304	-45304	-45304	-00304	-00304
4.777 to 4.818	4.781	-11306	-11306	-31306	-31306	-45306	-45306	-00306	-00306
4.808 to 4.849	4.812	-11308	-11308	-31308	-31308	-45308	-45308	-00308	-00308
4.839 to 4.880	4.843	-11310	-11310	-31310	-31310	-45310	-45310	-00310	-00310
4.871 to 4.912	4.875	-11312	-11312	-31312	-31312	-45312	-45312	-00312	-00312
4.902 to 4.943	4.906	-11314	-11314	-31314	-31314	-45314	-45314	-00314	-00314
4.933 to 4.974	4.937	-11316	-11316	-31316	-31316	-45316	-45316	-00316	-00316
4.964 to 5.005	4.968	-11318	-11318	-31318	-31318	-45318	-45318	-00318	-00318
4.996 to 5.037	5.000	-11320	-11320	-31320	-31320	-45320	-45320	-00320	-00320

TOOL SERIES: 5612 RANGE: 5.031" TO 5.500"								Cage Number	
Tool Size Range	Tool Nominal Diameter	Standard Tool Number Thru Style (11)		Standard Tool Number Blind Style (31)		Full Bottoming Tool Number Style (45)		Standard	Full Bottoming
		Straight Shank 5612-	Morse Taper Shank 5612-	Straight Shank 5612-	Morse Taper Shank 5612-	Straight Shank 5612-	Morse Taper Shank 5612-		
5.027 to 5.068	5.031	101-11322	-201-11322	-101-31322	-201-31322	-102-45322	-202-45322	5612-011-00322	5612-015-00322
5.058 to 5.099	5.062	-11324	-11324	-31324	-31324	-45324	-45324	-00324	-00324
5.089 to 5.130	5.093	-11326	-11326	-31326	-31326	-45326	-45326	-00326	-00326
5.121 to 5.162	5.125	-11328	-11328	-31328	-31328	-45328	-45328	-00328	-00328
5.152 to 5.193	5.156	-11330	-11330	-31330	-31330	-45330	-45330	-00330	-00330
5.183 to 5.224	5.187	-11332	-11332	-31332	-31332	-45332	-45332	-00332	-00332
5.214 to 5.255	5.218	-11334	-11334	-31334	-31334	-45334	-45334	-00334	-00334
5.246 to 5.287	5.250	-11336	-11336	-31336	-31336	-45336	-45336	-00336	-00336
5.277 to 5.318	5.281	-11338	-11338	-31338	-31338	-45338	-45338	-00338	-00338
5.308 to 5.349	5.312	-11340	-11340	-31340	-31340	-45340	-45340	-00340	-00340
5.339 to 5.380	5.343	-11342	-11342	-31342	-31342	-45342	-45342	-00342	-00342
5.371 to 5.412	5.375	-11344	-11344	-31344	-31344	-45344	-45344	-00344	-00344
5.402 to 5.443	5.406	-11346	-11346	-31346	-31346	-45346	-45346	-00346	-00346
5.433 to 5.474	5.437	-11348	-11348	-31348	-31348	-45348	-45348	-00348	-00348
5.464 to 5.505	5.468	-11350	-11350	-31350	-31350	-45350	-45350	-00350	-00350
5.496 to 5.537	5.500	-11352	-11352	-31352	-31352	-45352	-45352	-00352	-00352

Burnishing Length: UNLIMITED

Larger sizes available

SPARE PARTS											Shanks and Housings		
TOOL SERIES: 5610 RANGE: 3.343" TO 4.062"													
Tool Nominal Diameter	Cage Sleeve Number	Adapters	Mandrel Tip Number		Size	ROLLS							
			Standard	Bottoming		Standard		Blind-Style		Full Bottoming			
						Number Per Set	Part Number	Number Per Set	Part Number	Number Per Set	Part Number		
3.343	5410-074-00000	5350-092-00000	5155-059-10001	5155-059-10002	.468	11	5100-701-00468	11	5100-704-00468	11	5100-708-00468		
3.375			-060-	-060-									
3.406			-061-	-061-									
3.437			-062-	-062-									
3.468			-063-	-063-									
3.500			-064-	-064-									
3.531			-065-	-065-									
3.562			-066-	-066-									
3.593			-067-	-067-									
3.625			-068-	-068-									
3.656			-069-	-069-									
3.687			-070-	-070-									
3.718			-071-	-071-			.531	11	5100-701-00531	11	5100-704-00531	11	5100-708-00531
3.750			-072-	-072-									
3.781			-073-	-073-									
3.812			-074-	-074-									
3.843	-075-	-075-											
3.875	-076-	-076-											
3.906	-077-	-077-											
3.937	-078-	-078-											
3.968	-079-	-079-											
4.000	-080-	-080-											
4.031	-081-	-081-											
4.062	-082-	-082-											

TOOL SERIES: 5611 RANGE: 4.093" TO 5.000"											Shanks and Housings								
TOOL SERIES: 5611 RANGE: 4.093" TO 5.000"																			
Tool Nominal Diameter	Cage Sleeve Number	Adapters	Mandrel Tip Number		Size	ROLLS													
			Standard	Bottoming		Standard		Blind-Style		Full Bottoming									
						Number Per Set	Part Number	Number Per Set	Part Number	Number Per Set	Part Number								
4.093	5410-074-00000	5610-092-00001	5155-083-10001	5155-083-10002	.531	11	5100-701-00531	11	5100-704-00531	11	5100-708-00531								
4.125			-084-	-084-															
4.156			-085-	-085-															
4.187			-086-	-086-															
4.218			-087-	-087-															
4.250			-088-	-088-															
4.281			-089-	-089-															
4.312			-090-	-090-															
4.343		-091-	-091-																
4.375		-092-	-092-																
4.406		-093-	-093-																
4.437		-094-	-094-																
4.468		-095-	-095-																
4.500		-096-	-096-																
4.531		-097-	-097-																
4.562		-098-	-098-																
4.593	-099-	-099-																	
4.625	-100-	-100-																	
4.656	-101-	-101-																	
4.687	-102-	-102-			13	5100-701-00531	13	5100-704-00531	13	5100-708-00531									
4.718	-103-	-103-																	
4.750	-104-	-104-																	
4.781	-105-	-105-																	
4.812	-106-	-106-																	
4.843	-107-	-107-																	
4.875	-108-	-108-																	
4.906	-109-	-109-																	
4.937	-110-	-110-																	
4.968	-111-	-111-																	
5.000	-112-	-112-																	

TOOL SERIES: 5612 RANGE: 5.031" TO 5.500"											Shanks and Housings								
TOOL SERIES: 5612 RANGE: 5.031" TO 5.500"																			
Tool Nominal Diameter	Cage Sleeve Number	Adapters	Mandrel Tip Number		Size	ROLLS													
			Standard	Bottoming		Standard		Blind-Style		Full Bottoming									
						Number Per Set	Part Number	Number Per Set	Part Number	Number Per Set	Part Number								
5.031	5410-074-00000	5611-092-00002	5155-113-10001	5155-113-10002	.531	13	5100-701-00531	13	5100-704-00531	13	5100-708-00531								
5.062			-114-	-114-															
5.093			-115-	-115-															
5.125			-116-	-116-															
5.156			-117-	-117-															
5.187			-118-	-118-															
5.218			-119-	-119-															
5.250			-120-	-120-															
5.281		-121-	-121-																
5.312		-122-	-122-																
5.343		-123-	-123-																
5.375		-124-	-124-																
5.406		-125-	-125-																
5.437		-126-	-126-																
5.468		-127-	-127-																
5.500		-128-	-128-			15		15		15									

Burnishing Length: UNLIMITED  
Larger sizes available

Straight Shank 5410-041-00000 Morse Taper Shank 5410-042-00000  
All Sizes Housing Assemblies 5410-182-00000

## DIAMOND BURNISHING TOOLS

- Eliminates grinding and polishing
- Produces ultra-smooth surface finish
- Slim-line design for tight areas
- Replaceable diamond stems
- Simple to use
- Affordable for all shops



Diamond Tool S2300-00

### Obtain an ultra-smooth surface finish!

All Elliott Diamond Burnishing Tools are made with selected diamonds which will burnish turned or ground surfaces of most metals to a high-quality, 2 to 8 microinch finish. Cast iron can be burnished as low as 15 RMS.

### Slim-line design!

The slim-line design has a 3/4" shank. This makes the tool ideal for smaller lathes and allows for close approaches. The offset design sets the tool on correct centerline. The diamond burnishing tool is now available with a 1" square shank; tool number S2300A00. It is also available in a kit; part number S2300AKIT.

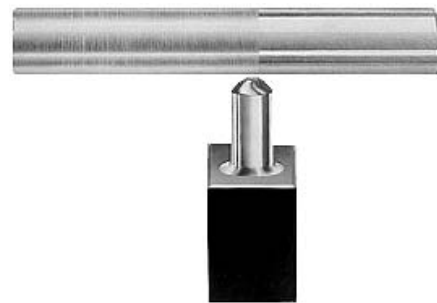

Shows typical diamond tool at work.

### Easy to use!

The tool mounts in the tool post of a lathe or turning center. The tool holder is set so that the diamond contacts the work at the center of the part at a 90° angle to its surface.

The Diamond Burnishing Tool is used in linear applications. As the part is turned, the diamond, under spring pressure, is fed across at a feed rate of .003" to .004" per revolution at a maximum of 750 SFM.

### Economical and affordable for all shops!

The Diamond Burnishing Tool offers a low-cost method of finishing parts under R40 to a 2 to 8 microinch finish. The tool has a disposable insert with a precision ground natural diamond mounted on the tip. When the diamond wears, the diamond stem is easily replaced.

The Diamond Tool can burnish interrupted surfaces. This is accomplished by setting the internal spring mechanism to allow a maximum of .005" movement during burnishing.



Diamond Kit S2300-Kit

## ELLIOTT OUTSIDE-SURFACE CARBIDE-ROLLER BURNISHING TOOLS

- Reduce costs by eliminating secondary operations
- Suitable for most CNC turning centers
- Economical tool life with carbide roller
- Produce 5 to 8 microinch finishes (0.13-0.20  $\mu\text{m}$ ) in one pass

### Burnish multiple surfaces after turning

The Outside Surface Carbide Roller Burnishing Tool is mounted in the turret of a CNC turning center.

Part surfaces are turned to an 80 to 100 microinch finish using speeds consistent with good machining practices. The carbide tool then follows the same path at comparable speeds to the turning operation, producing a 5 to 8 microinch finish. This eliminates secondary operations and additional equipment.

The tool is offered in two different designs, one for spherical work and the other for linear surfaces. Rolls are available from stock in four radii; .031", .062", .093" and .125".



Tool Number	Style	Shank	Left/Right Hand	Roll Radius
S2075-00	Outside Surface	1"	Left	0.031
S2121-00	Outside Surface	1"	Right	0.031
S2548-00	Outside Surface	1"	Left	0.062
S2549-00	Outside Surface	1"	Right	0.062
S2233-00	Outside Surface	1"	Left	0.093
S2327-00	Outside Surface	1"	Right	0.093
5900-100-80477	Outside Surface	1"	Left	0.125
5900-100-80558	Outside Surface	1"	Right	0.125
S2302-00	Outside Surface	3/4"	Left	0.031
S2306-00	Outside Surface	3/4"	Right	0.031
S2427-00	Outside Surface	3/4"	Left	0.093
S2488-00	Outside Surface	3/4"	Right	0.093
S2313-00	Outside Surface	1 1/4"	Left	0.031
S2384-00	Outside Surface	1 1/4"	Right	0.031

\*\*\*Other sizes available upon request  
 \*\*\*All tools available with metric shanks

## BORING BAR STYLE CARBIDE-ROLLER BURNISHING TOOLS

- Reduce machining costs
- Eliminate secondary operations
- Burnish on CNC turning centers
- Economical tool life with carbide rolls
- Produce 5 to 8 microinch finishes (0.13-0.20  $\mu\text{m}$ )

**Model S2320-00** (shown at top right) with an .032" radius roll is for medium reaches and has an overall tool length of 12".

**Model S2320A00** (shown at bottom right) with an .032" radius roll is preferred for deeper reaches and larger I.D.'s. With its 1-3/4" diameter roll and an 18" overall tool length, it is ideal for larger horizontal and vertical turning centers. Parts with diameters 2-1/4" and greater can be burnished with this tool.

**Model S2340-00** is for medium reaches and has an overall tool length of 12" with .093" radius roll. **Model S2340A00** is available in an 18" overall length.

**Model S2289-00** (not shown) is ideal for smaller parts and turning centers, with its 1-3/16" diameter roller and 9.5" overall tool length. This tool can burnish inside diameters as small as 1-3/8" and reaches up to 3" with .032" radius roll. **Model S2289A00** has a .093" radius roll.

The carbide roller is spring loaded in two axial directions to provide the correct pressure for burnishing. The roller can be reground many times as a tooling cost savings.



Tool Number	Style	Shank	Roll Radius
S2289-00	Boring Bar	1 1/2" Round	0.031
S2289A00	Boring Bar	1 1/2" Round	0.093
S2320-00	Boring Bar - 12" OAL	2" Round	0.031
S2320A00	Boring Bar - 18" OAL	2" Round	0.031
S2340-00	Boring Bar - 12" OAL	2" Round	0.093
S2340A00	Boring Bar - 18" OAL	2" Round	0.093
CB127-00	Boring Bar - 12" OAL	2" Round	0.062
CB168-00	Boring Bar - 18" OAL	2" Round	0.062

\*\*\*Other sizes available upon request  
 \*\*\*All tools available with metric shanks





**ELLIOTT**  
TOOL TECHNOLOGIES

[www.elliott-tool.com](http://www.elliott-tool.com)

## ADDITIONAL PRECISION PRODUCTS



### Monaghan I.D. Roller Burnishing Tool

Produces superior finish with precise size control. Easy adjustments in increments of .0001".



### Monaghan O.D. Roller Burnishing Tool

Produces superior finish with precise size control. Easy adjustments in increments of .0001".



### Outside Surface Carbide Roller Burnishing Tool

Burnish O.D. surfaces and land faces. Use on any machine where the part is rotating.



### Diamond Burnishing Tool

Economical way to burnish O.D. surfaces and faces. Produces 2 to 15 microinch finish. Replaceable diamond stems.



### IRU Internal Recessing Unit

Superior tool for deep bore recessing, multiple grooves and multiple chamfers.



### BCU Back Chamfering Unit

Positive machined back chamfers with interchangeable cutters and pilots. Cutters can be re-ground. Excellent for deburring.



### Elliptical Deburring Tool

Chamfer hole edges, uniform burr removal. Cutters follow the hole circumference.



### Mechanical Joining Tool

Join tubular products to flanges and fittings. The mechanical joint will not leak, pull off or vibrate loose when properly installed. For use on hydraulic or pneumatic applications.

1 937 253-7706 Telephone  
1 800 732-4565 Toll Free  
1 937 259-9241 Fax

[www.monaghaninc.com](http://www.monaghaninc.com)

Marketed by:



1760 Tuttle Ave., Dayton, Ohio 45403